

PRESSURE RELIEF VALVE



The valve is applied to prevent overload in lubrication systems. It is mounted on the pump pressure line or on the outlet ports of progressive dosing distributors. In this way the equipment is protected from damage. Is produced in two versions:

- safety valve with connection pipe F10
- safety valve with connecting thread M14x1,5

On customer request on made the valves with other working pressure, as well as the connection type.

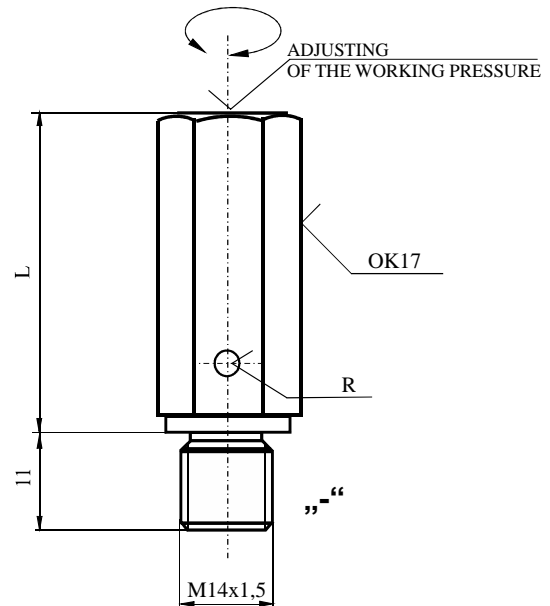
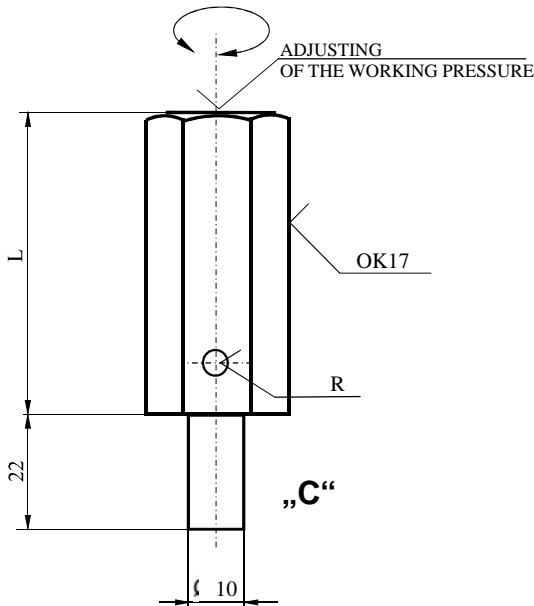

Ordering code	"C"	10 - 0400 C	10 - 0400/1 C	10 - 0400/2 C
	-	10 - 0400	10 - 0400/1	10 - 0400/2
Fluid	oil viscosity	>13 mm ² /s		
	grease	NLGI ≤3		
	temperature	-30 ; +80 °C		
Operating pressure		100 - 300 bar	10 - 70 bar	150 - 450 bar
Flow rate		NO3	NO4	NO3
L		45 mm	51 mm	59 mm
Connecting port		M14x1,5		
Mass		~ 0,1kg		

SYMBOL:

