

PNEUMATIC DRIVEN PUMP FOR SINGLE LUBRICATION

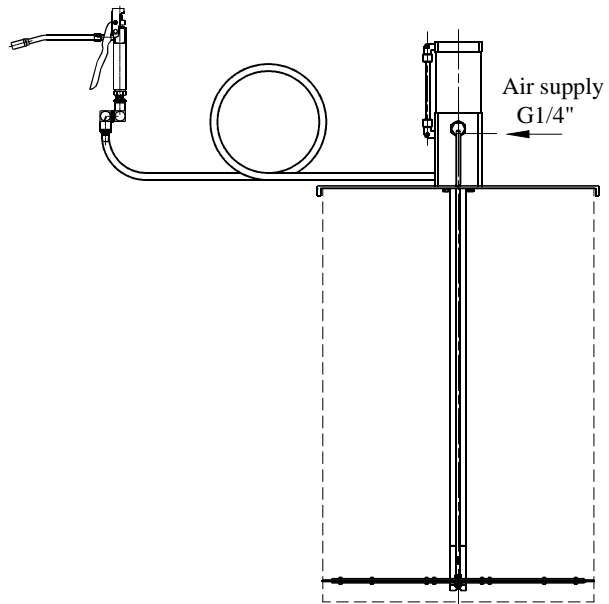

Pneumatic pump for single lubrication type 10-5100 is applied for single lubrication in service work-shops as well as in outdoor, where the supply of pressurized air is available. It is suitable for operation in very hard working conditions (excavators for surface exploitation, iron plants, cement works). This piston pump is designed to be directly mounted to a standard lubricant barrel of 200 dm³. It is equipped with high pressure flexible hose NP8 length of 15m and lubrication gun with swivel fitting which allows turning gun on three axis and easy handling, regardless of rigidity hoses under high pressure. For uniform work of the pump pressurized air must be clean and lubricated. Only in this case is recognized warranty on the device.

The option with set for air purification is also available (code 10-5100 P).

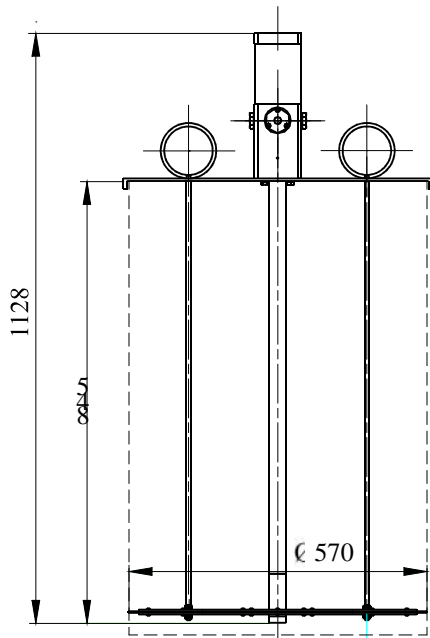

Ordering code	10-5100	
Fluid	Oil viscosity	>13 mm ² /s
	Grease	NLGI <3
	Temperature	-10 ; +60 °C
Air pressure	max. 6 bar	
Lubricant pressure	max. 400 bar	
Flow/cycle	5,5 cm ³	
Cycle per minute	120	
Length hose	15 m	
Mass	30 kg	

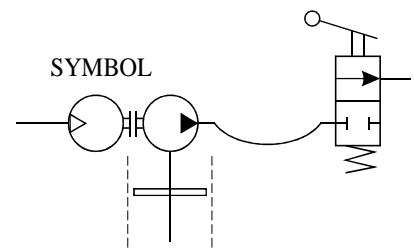

SERBIA
 36210 VRNJACKA BANJA
 Rudjinci 175/A
 tel/fax: +381 - 36 - 631 - 710
 631 - 711
 E-mail: office@fluidotehnic.com