

HAND OPERATED PUMP (FOR LUBRICANT TRANSFER)

Hand pump type 10-2400 is applied for charging other pumps in small lubrication systems. The pump design is based on the principle of a double - acting piston. It is of simple design suitable for carrying. The pump is equipped with tank for lubricant. The proper flexible hose can be added on request.

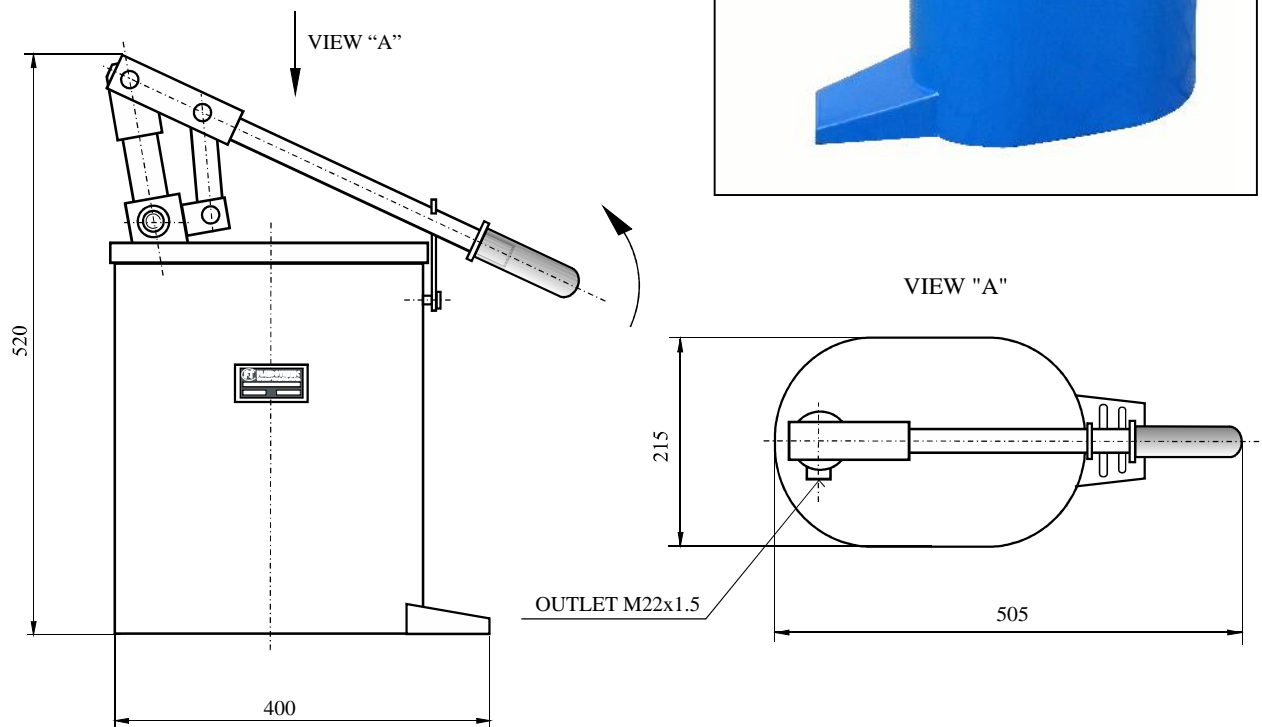

Ordering code	10 - 2400	
Fluid	Oil viscosity	>13 mm ² /s
	Grease	NLGI <3
	Temperature	-10 ; +80 °C
Operating pressure	max. 10 bar	
Flow per cycle	100 cm ³	
Force on lever under max. pressure	20 daN	
Connection ports	M22x1,5	
Tank volume	15 dm ³	
Mass	7,0 kg	

SYMBOL:

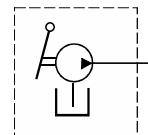

SERBIA
 36210 VRNJACKA BANJA
 Rudjinci 175/A
 tel/fax: +381 - 36 - 631 - 710
 631 - 711
 E-mail: office@fluidotehnic.com