

DUBLE PRESSURE LINE FILTER



Duble pressure line filter is applied for oil circulating lubrication systems for middle and high power gearboxes. It is capable for operation in very hard conditions. The filter can be assembled in pressure line in any position. Flow direction is indicated by the arrow on the filter body. The filter cartridge is made of high strength wire cloth. Periodically it is necessary to wash the filter cartridge in the gasoline. To disassembling unscrew the filter cup. The cleaning period depends of the operating time and of the grease purity

Filter has three operation modes so that the filter cartridge can be changed without stopping the flow, i.e. diversion of flow can be rerout to the other filter element.

Filthiness filter can be determined visually and by electro indicator.

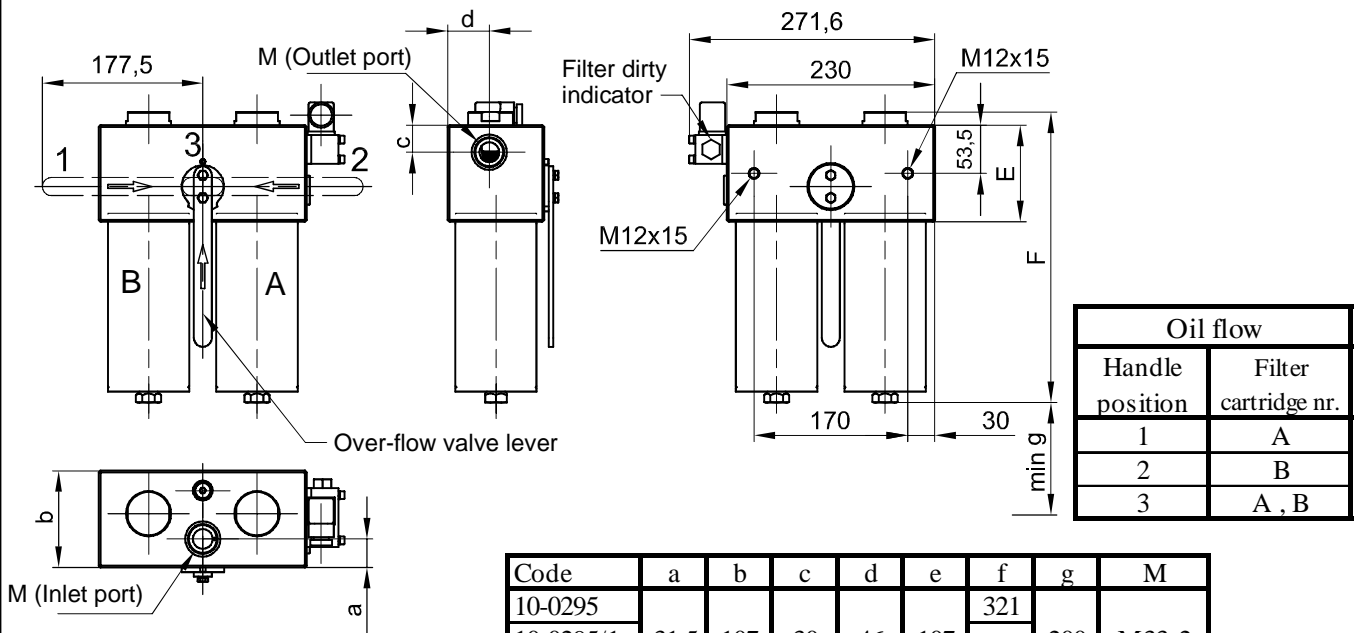

Code	a	b	c	d	e	f	g	M
10-0295						321		
10-0295/1	31,5	107	30	46	107	268	200	M33x2
10-0295/2								
10-0295/3	38	125	35	49	140	466	320	M42x2

Ordering code	10-0295	10-0295/1	10-0295/2	10-0295/3
Fluid	Oil viscosity >13 mm ² /s			
	Temperature -30 do +80 °C			
Operating pressure	20 bar			
Filtration rating	40, 60, 100, 150, 200, 300 μm			
Flow rate	100 dm ³ /min	40 dm ³ /min	25 dm ³ /min	180 dm ³ /min
Contaminant indicator	switch type magnetic			
	voltage max 250V AC/DC			
	working load 1,2W			
	diff.activated pressure p=2 bar			
Mass	22 kg	20 kg	20 kg	36 kg

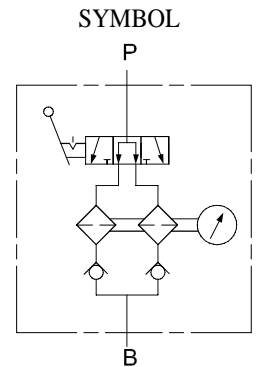

SERBIA
36210 VRNJACKA BANJA
Rudjinci 175/A
tel/fax: +381 - 36 - 631 - 710
631 - 711
E-mail: office@fluidotehnic.com